

Full-Height Turnstile

DR.TD.6771-1

SHENZHEN DOOR INTELLIGENT CONTROL
TECHNOLOGY CO.,LTD



Structure Parameter

Material: SUS304 brushed stainless steel

Top cover 2.0mm, whole body 1.5mm

Arm: stainless steel

Technical Parameter

Passage Width: $\leq 650\text{mm}$

Passing Speed: 20~35 person/min

Working Temperature: $-20^{\circ}\text{C} \sim +60^{\circ}\text{C}$

Mean Cycles Between Failure: 3 million times IP

Rating: IP65

Electric Parameter

Voltage: AC110V/AC220V $\pm 10\%$ 50-60Hz

Driving Motor: Solenoid valve control

Dimensions: L1580 \times W1500 \times H2310mm

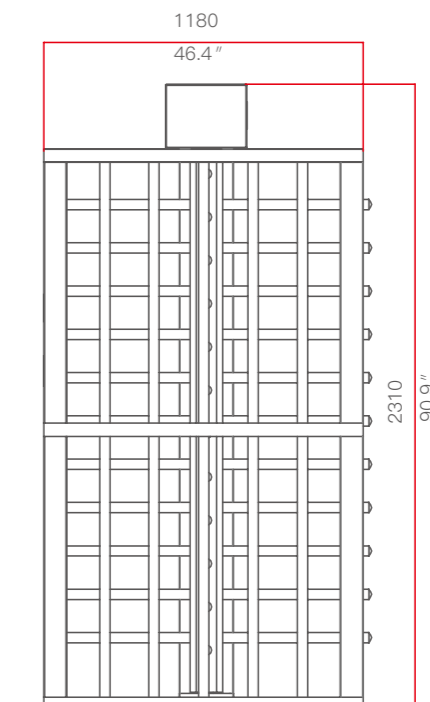
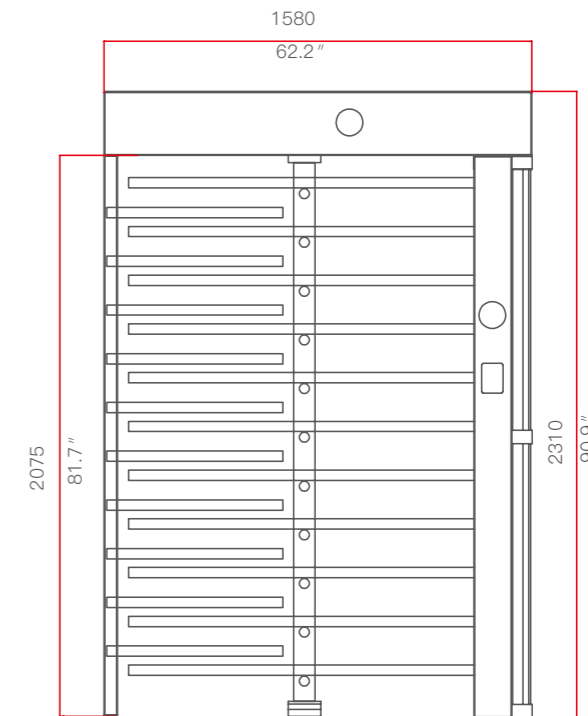

Field of Application

Stadiums;

Amusement parks;

Water parks;

Scenic spots;

Gymnasium.

